

Specification of: PFP A3-0280 1.4kW 230V-1F M6F0

Direct driven high-performance centrifugal fan PFP

Complete plug fan module with high system efficiency, provided with front panel and supporting frame, suitable for horizontal or vertical installation, specifically developed and optimized for use without a scroll case. Equipped with flow measuring device IMV as a standard feature. Aluminium-made centrifugal impeller with 7 backward inclined welded blades. The wheel is directly fitted to a brushless external-rotor motor, with no transmission losses. The complete unit is dynamically balanced according to DIN ISO 21940-11. Light-weight motor frame cast from corrosion-resistant aluminium. A single-phase sensorless driver is fully integrated into the motor and is provided with an active PFC (Power Factor > 0.95 in any state of operation). Continuous speed control of the Drive System by 0 ... 10 V analogue signal, or with Modbus RS485-compliant interface. All the drive system is protected according to class IP 55. Power supply 230 V – 50/60 Hz. Air performance ratings according to AMCA 210-07 (Fig. 12) and ISO 5801:2007 (Fig. 41 and par. 30.3).

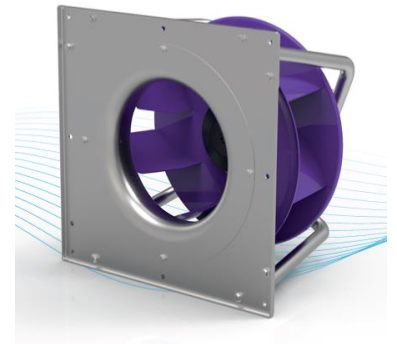

Technical data of the fan: PFP A3-0280 1.4kW 230V-1F M6F0

fulfills the ErP requirements 2015

Description	Value Dimension
Installation acc. DIN 24163 Part 1	A
Reference density (ρ_{ref})	1.20 kg/m ³
Medium temperature (t)	20 C
Fan weight	12 kg
Feed data	
Main's frequency (f_N)	50/60 Hz
Voltage (U_N)	1~ 230 V
Phases-Voltage-Frequency	1~230-50 V-Hz
Power (P_N)	0 kW
operational limits	
Max. fan speed (n_{vmax})	3350 min ⁻¹
Max. absorbed power of the system (P_{maxS})	1.40 kW
max. current: Inverter out resp. control unit in (I_{max})	5.9 A
Temperature range for conveying medium ($t_{min} \dots t_{max}$)	-20...40 C
ErP-Data at best efficiency and density - kg/m³	
measurement- / efficiency category	A / static
design status of VSD	VSD is integrated
overall efficiency ($\eta_{A,opt}$)	56.9 %
achieved efficiency grade (N_{ist})	66.4
required efficiency grade in 2013 / 2015 (N)	58 / 62
Air flow rate (V_{opt})	2586 m ³ /h
pressure rise (dp_{opt})	979 Pa
Fan speed (n_{vopt})	3315 min ⁻¹
motor power input (P_{1opt})	1.24 kW
specific ratio (d_{dopt})	1.010

Fan curve to PFP A3-0280 1.4kW 230V-1F M6F0

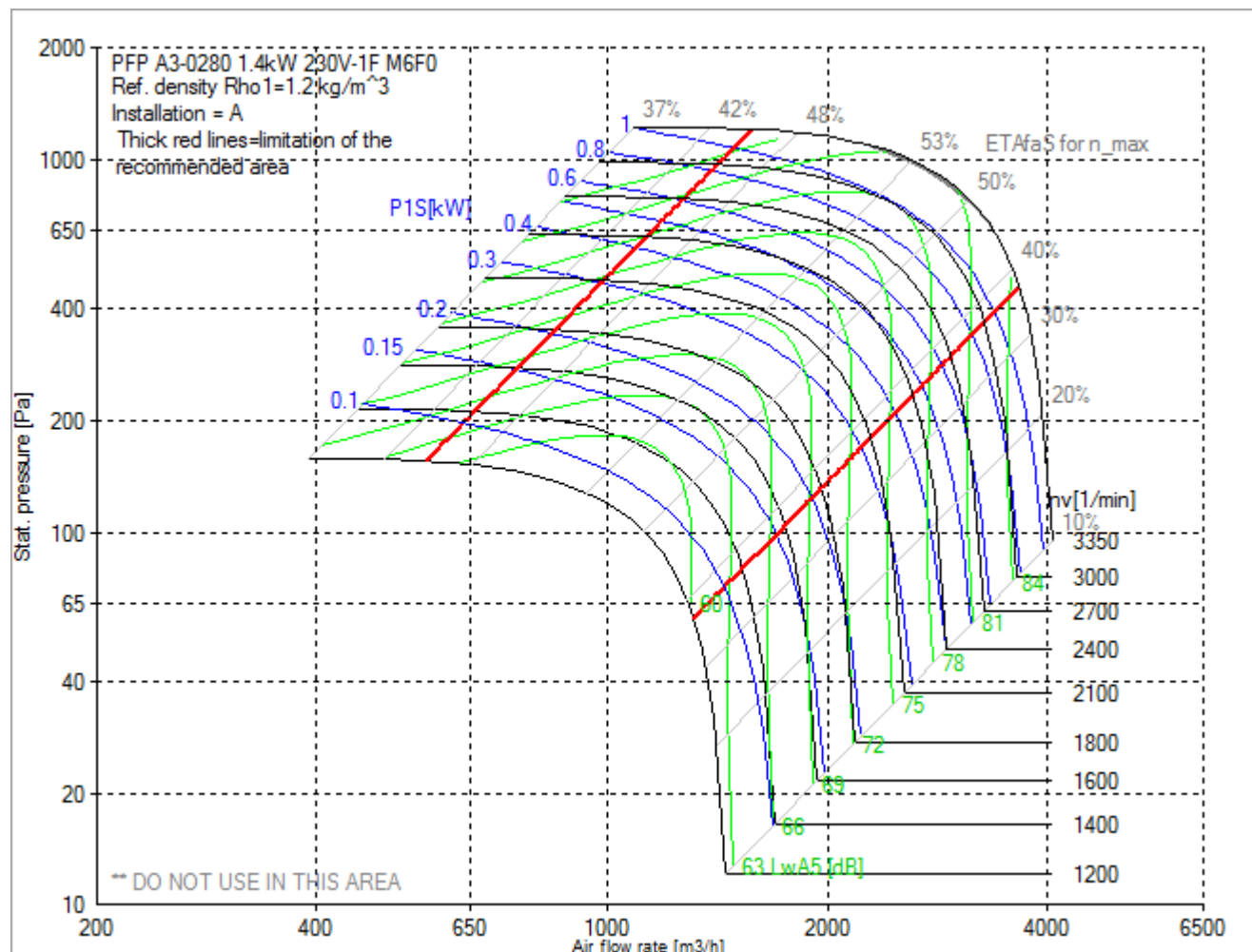

Dimensions to PFP A3-0280 1.4kW 230V-1F M6F0

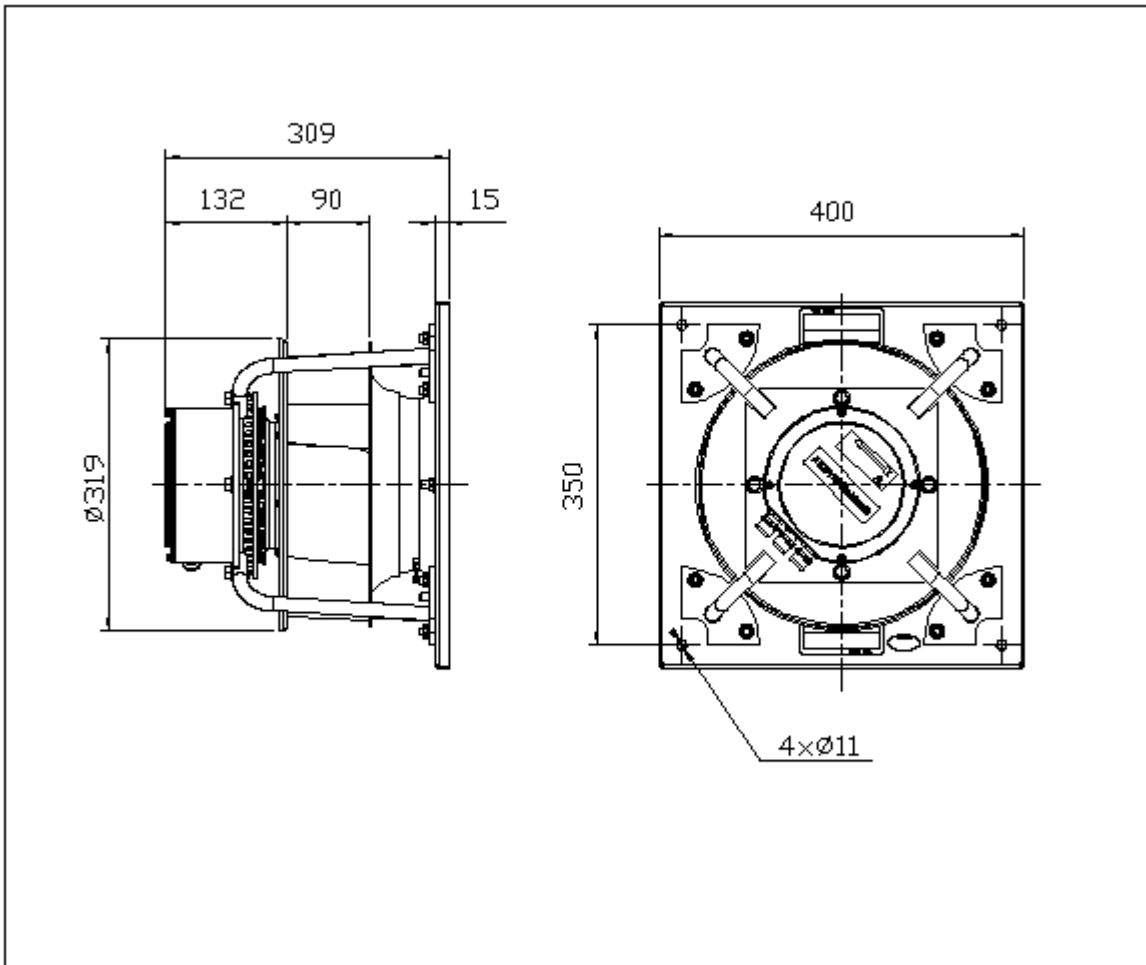

Rotation:
Handing:

RD
90

Wiring diagram of the fan PFP A3-0280 1.4kW 230V-1F M6F0

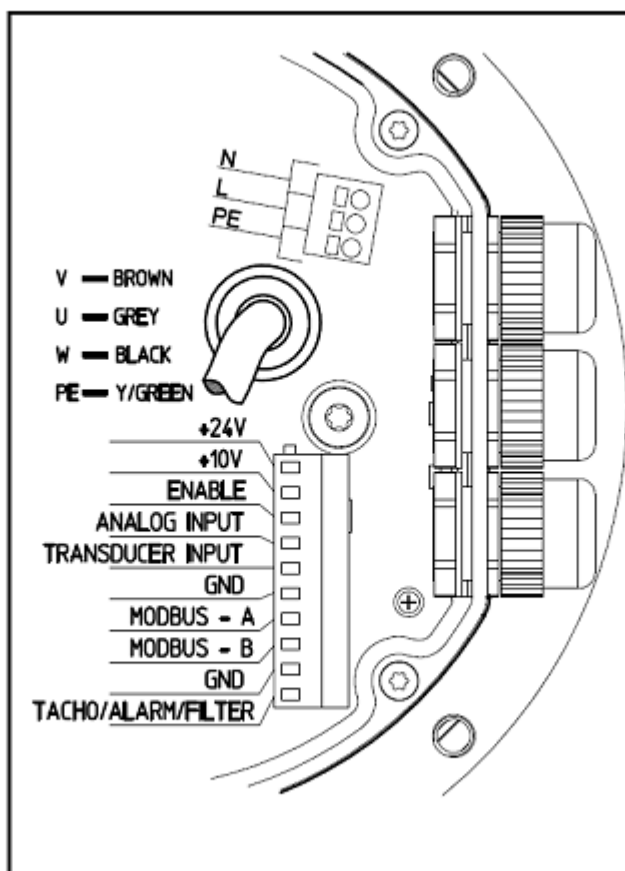

14-07-2017 9X

Wiring diagram for connection to: [mains - VSD - motor](#)
 Rotation: [LG](#)